

1. Saša PRODANOVIĆ, 2. Novak NEDIĆ

## ANALYSIS OF POSSIBILITIES FOR DISTURBANCE REJECTION IN THE DECOUPLED MULTIVARIABLE PROCESS

1. University of East Sarajevo, Faculty of Mechanical Engineering, East Sarajevo, BOSNIA & HERZEGOVINA

2. University of Kragujevac, Faculty of Mechanical and Civil Engineering in Kraljevo, SERBIA

**Abstract:** Proper behavior of multivariable process isn't guaranteed only through the disabling influence of its mutual coupling (interaction), but also compensation of disturbance has very important role. Investigation of disturbance that can be rejected by previously decoupled 2x2 process has been presented in this paper. Considered flow tank, as a multivariable process, was controlled using PI controllers. The aim was to determine limit of disturbance intensity under whose influence system can operate correctly, and in that way additionally check validity of designed decoupler, i.e. chosen non-conventional control. General expression for periodic rising signal that can be introduced into process in order to present array of disturbances has been derived, too. Investigation was supported by simulations.

**Keywords:** disturbance, non-conventional control, PI controller, flow tank

### INTRODUCTION

Numerous researches have been presented the advantages of non-conventional control system containing decoupler in its controller over approach where mutual coupling wasn't taken into consideration. In one of them [1], control system of level and temperature in 2x2 flow tank has been investigated. Analysis of interaction among its inputs and outputs was carried out using theory given in [2] and decoupler has been designed like in [3]. Previously, process was modeled in [4] using physical laws and experiential data. Parameters of PI controller were determined based on principles given in [5] without need for repeating relay feedback test like in [6]. Beside reference tracking, researched and confirmed in [1], another very significant indicator of control quality is process ability to reject disturbances that occur during its operating. That is the main subject of this research. Here will be considered four cases of disturbance, that should serve to determine limits of its intensity which system can compensate.

### PROCESS AND ITS MODEL

Various types of plants in the chemical, pharmaceutical, food and other industries contain some kind of flow tanks where two fluids are mixed in order to obtain their blend. Flow tank with water as a fluid that come through the two valves, 1 and 2, whose temperatures are  $t_1=15^\circ\text{C}$  and  $t_2=70^\circ\text{C}$ , respectively, was researched. Water is mixed on the

constant number of revolutions. One or more properties of final fluid through the outlet valve 3 (on/off type, flow rate  $Q_3$ ) can be controlled. Demand for temperature control comes from production technology. Level in the tank should be maintained on the specified value in order to provide proper mixing of components. Therefore, in present 2x2 process, inputs are flow rates ( $Q_1$  or  $Q_2$ ) through the valves 1 and 2. Outputs are level  $h$  and temperature  $t$ . Reference values are taken to be 1m for level, and  $30^\circ\text{C}$  for temperature. Mathematical model for this type of flow tank, derived in [4], is expressed with following transfer function matrix:

$$G(s) = \begin{bmatrix} g_{11}(s) & g_{12}(s) \\ g_{21}(s) & g_{22}(s) \end{bmatrix} = \begin{bmatrix} \frac{K}{Ts+1} & \frac{K}{Ts+1} \\ \frac{K_1}{T_1s+1} e^{-L_1s} & \frac{K_2}{T_2s+1} e^{-L_2s} \end{bmatrix} \quad (1)$$

where:  $g_{ij}(s)$  – elements of transfer function matrix,  $K$ ,  $K_1$  and  $K_2$  – gains,  $T$ ,  $T_1$  and  $T_2$  – time constants,  $L_1$  and  $L_2$  – delay times.

### ANALYSIS OF DISTURBANCE

Analysis of process behaviour in the presence of disturbance is extension in checking of control strategy for considered flow tank. Square shape of disturbance was taken and it is assumed that they appear in the steady state. To enhance efficiency of test, the disturbances were introduced sequentially with defined period and in rising order of their

intensity (more precisely, its absolute value). Whereas disturbances aren't measured, the feedback control is obvious here. General form of used disturbance is expressed by equation (2).

$$d = \begin{cases} 0, & t \in (0, t_0) \cup \bigcup_{j=1}^n (t_0 + t_p(j-1) + \Delta t, t_0 + t_p j) \\ [0, i], & t = t_0 + t_p(i-1) \\ i, & t \in (t_0 + t_p(i-1), t_0 + t_p(i-1) + \Delta t) \\ [i, 0], & t = t_0 + t_p(i-1) + \Delta t \end{cases}$$

$i = 1, 2, \dots, n$  (2)

where are:  $t_0$  – time of introducing of the first disturbance,  $t_p$  – period between starts of the adjacent disturbances,  $\Delta t$  – disturbance duration,  $i$  – disturbance intensity,  $d_i$  – ordinal number of disturbance,  $n$  – number of iterations. The meanings of values in equation (2) are shown in Figure 1.a). The part b) of this figure shows opposite direction of disturbance influence. Hence, this form can be used to determine limits of disturbance intensity. It offers opportunities for researching wide range of their intensity, but then they have to be scaled.

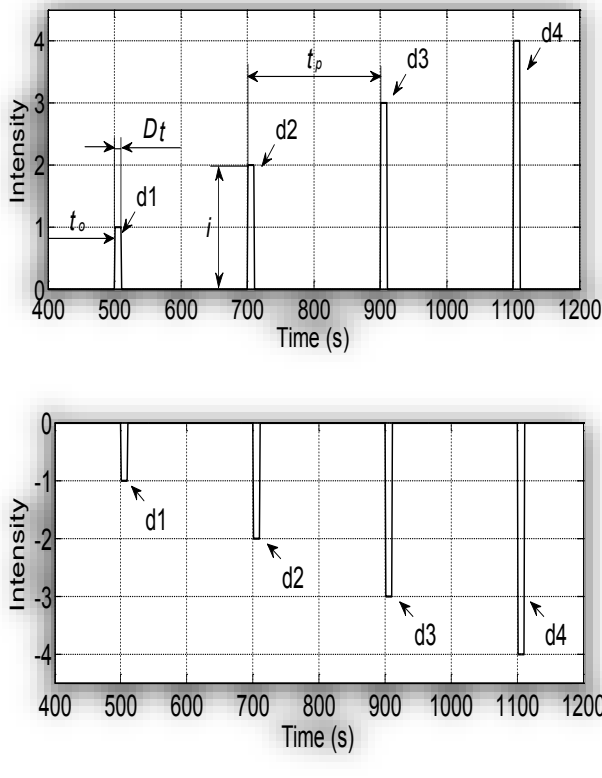

Figure 1. Array of square disturbance: a) positive direction, b) negative direction

In this survey following values have been chosen:  $t_0=500$  s,  $t_p=200$  s,  $\Delta t=10$  s,  $n=4$ . Boundary for acceptable intensity are 10% of overshoot and undershoot. Analysis was performed through the considering process responses in presence of disturbance.

That was realised using simulations, which need block diagram of entire control system shown in

Figure 2. This block diagram, except disturbance, was formed in [1,4], where I/P transducer is current-pneumatic transducer and  $U$  and  $X_i$  are manipulated and controlled variable, respectively.

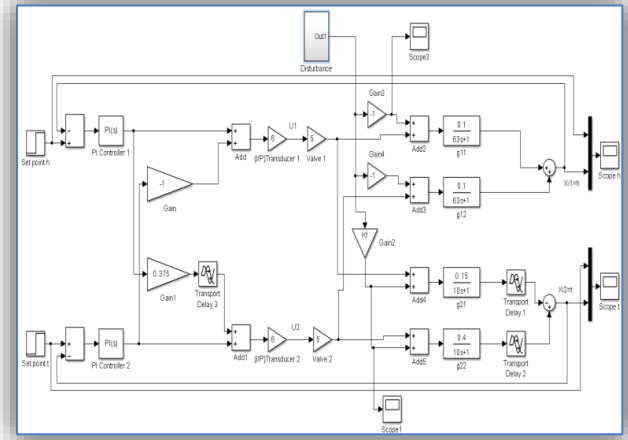

Figure 2. Block diagram of the control system of level and temperature in decoupled flow tank with introduced disturbance

≡ **First case – increasing of level and temperature (h+,t+)**

Hot water on temperature of 100°C is adding into tank with flow rate which scaled values is between (1–4). Exact ratio between disturbance and its scaled value can be determined experimentally. That implies its scheduling till equalization of process responses obtained from simulations with its real equivalent, where upon it can be related with certain value  $i$  in equation (2).

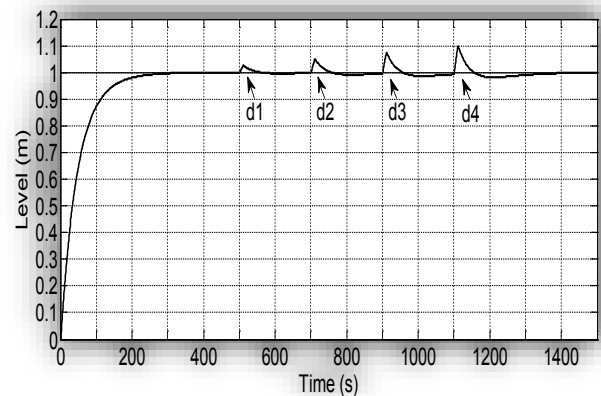
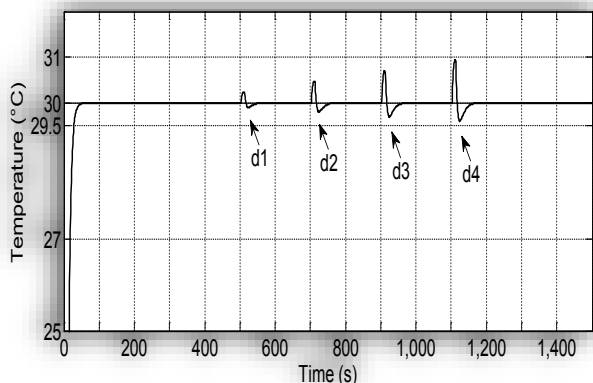

Figure 3. Level in flow tank under influence of disturbance (h+,t+)

Effects of disturbance on the process outputs depend on terms in transfer function matrix, too. But for completing definition of disturbance effect, relation between fluid volume and temperature should be calculated and it is presented through the correction factor  $K_f$ . This is carried out using law of conservation of energy, which for this flow tank is expressed by equation  $t_{r+1} = (V_r t_r + V_d t_a) / (V_r + V_d)$ , where  $t_{r+1}$  – temperature of blend after influence of disturbance,  $t_r$  – temperature of blend before

influence of disturbance,  $t_d$  – temperature of added water,  $V_r$  – volume in flow tank,  $V_d$  – volume of added water. Now correction factor is  $K_f = [(t_{r+} - t_r) / t_r] \cdot 100$ .

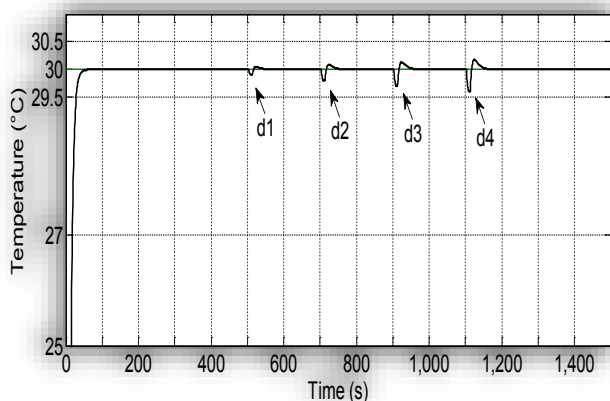

**Figure 4.** Enlarged view of temperature in flow tank under influence of disturbance ( $h+, t+$ )

In this first case  $K_f = 2,3$ . Simulations of four values of disturbance intensity, without gains 3 and 4 in Figure 2, give level in flow tank in Figure 3, while Figure 4 contains enlarged view of temperature in this tank.

≡ **Second case - increasing of level and decreasing of temperature ( $h+, t-$ )**

Equal volumes of mixed water and ice as in first case, but here on temperature of  $0^\circ\text{C}$  are adding into tank. Therefore, level is the same like in first case (Figure 3) and temperature, obtained after simulations of four values of disturbance intensity, without gains 3 and 4 in Figure 2, is shown in Figure 5. In this case correction factor is  $K_f = -1$ .

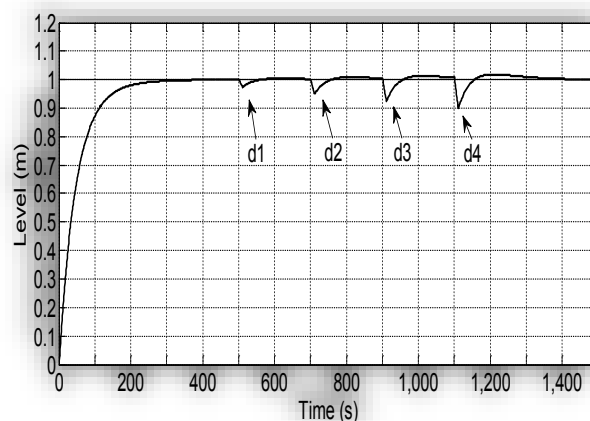

**Figure 5.** Enlarged view of temperature in flow tank under influence of disturbance ( $h+, t-$ )

≡ **Third case - decreasing of level and increasing of temperature ( $h-, t+$ )**

This case describes drop flow through the valve 1, and because of that, at the initial moment, more water come from valve 2. Temperature of that water is  $70^\circ\text{C}$  and it increases temperature of blend  $t_r$ . In this case correction factor is  $K_f = 1,3$ . Simulations carried out according block diagram in Figure 2

give level and temperature in flow tank shown in Figure 6 and 7, respectively.



**Figure 6.** Level in flow tank under influence of disturbance ( $h-, t+$ )

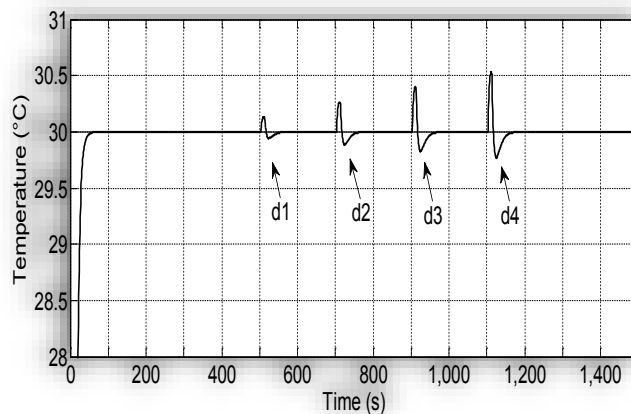

**Figure 7.** Enlarged view of temperature in flow tank under influence of disturbance ( $h-, t+$ )

≡ **Fourth case – decreasing of level and temperature ( $h-, t-$ )**

Drop flow (equal as in third case) through the valve 2 was simulated here, and because of that, at the initial moment, more water come from valve 1. Temperature of that water is  $15^\circ\text{C}$  and it decreases temperature of blend  $t_r$ . In this case correction factor is  $K_f = -0,5$ . Level is the same like in third case (Figure 6) and temperature is shown in Figure 8.

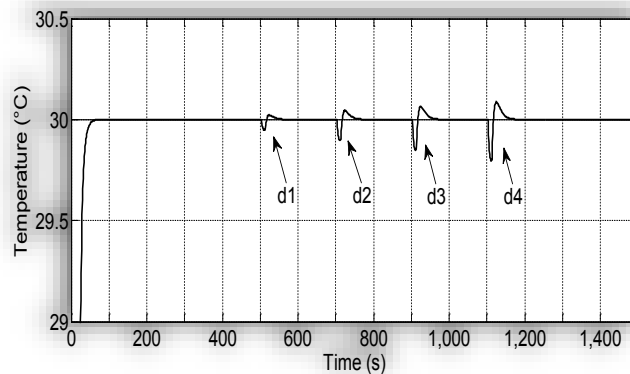

**Figure 8.** Enlarged view of temperature in flow tank under influence of disturbance ( $h-, t-$ )



## DISCUSSION OF RESULTS

As stated, limits within which response can be taken as good are  $\pm 10\%$ . Thus, for level limits are  $(0,9 \div 1,1)m$  and for temperature  $(27 \div 33)^\circ C$ . To determine settling time after influence of disturbance  $T_s$ , steady state error was defined  $\varepsilon = \pm 2\%$ . It is: for level  $\varepsilon = (0,98 \div 1,02)m$  and for temperature  $\varepsilon = (29,4 \div 30,6)^\circ C$ . Taking into account these limits and simulated responses, it is noticeable that disturbance has larger influence to the level. Numerous values of disturbance intensity were varied and it was found that responses weren't overcome limits up to forth level of intensity, as it shown in Figure 3-8. Another favorable result is that responses which overcome steady state error have very short settling time from the start of disturbance (highest in the level in first case  $T_s = 39,5$  s). Based on this, after mentioned scaling, the real values of water volume and its temperature, that can be added into flow tank as disturbance without undermining the good work of process, can be determined.

## CONCLUSION

This research supports efforts in forming general model for determining range for certain kind of disturbance that can be compensated by the feedback control system. In this regard, general model of rising disturbance in square form that occur in equal intervals has been derived. Considering flow tank, rejection will be better with larger  $Q_{3max}$ , because for higher disturbance intensities drainage flow rate should be higher, too. Regarding temperature, larger flexibility of control system can be enabled with valves which satisfy ratio  $Q_{3max} = 2 \cdot Q_{1max} = 2 \cdot Q_{2max}$ .

## Note:

This paper is based on the paper presented at The 12th International Conference on Accomplishments in Electrical and Mechanical Engineering and Information Technology – DEMI 2015, organized by the University of Banja Luka, Faculty of Mechanical Engineering and Faculty of Electrical Engineering, in Banja Luka, BOSNIA & HERZEGOVINA (29th – 30th of May, 2015), referred here as [7].

## REFERENCES

- [1] Prodanović, S., Nedić, N. (2014). Non-conventional control of level and temperature in the flow tank. COMETA2014 Conference Proceedings, Jahorina, B&H, p. 421-428. (in Serbian)
- [2] Skogestad, S. and Postlethwaite, I. (2005). Multivariable Feedback Control: Analysis and Design, 2nd ed. John Wiley & Sons, Chichester.
- [3] Morilla, F., Garrido, J., Vázquez, F. (2013). Multivariable decoupling control. Revista Ibero

americana de Automática e Informática industrial, vol. 10, p. 3-17. (In Spanish)

- [4] Prodanović, S. Lj., Nedić, N. N. and Brašić, V. S. (2014). Some Considerations of Mutual Coupling in Multivariable Processes, SAUM 2014 Conference Proceedings, Niš, Serbia, p. 257-260.
- [5] Filipović V. Ž., Nedić N. N. (2008). PID Controllers, University of Kragujevac, Faculty of Mechanical Engineering, Kraljevo. (in Serbian).
- [6] Menani, S. and Koivo, H. (2003). New approach on the automatic tuning of multivariable PI controllers using relay feedback. International Journal of Systems Science, vol. 34, no. 2, p. 93-110.
- [7] Saša Prodanović, Novak Nedić, Analysis of possibilities for disturbance rejection in the decoupled multivariable process, The 12th International Conference on Accomplishments in Electrical and Mechanical Engineering and Information Technology – DEMI 2015



**ACTA Technica CORVINIENSIS**  
BULLETIN OF ENGINEERING

**ISSN:2067-3809**

copyright ©

University POLITEHNICA Timisoara,  
Faculty of Engineering Hunedoara,  
5, Revolutiei, 331128, Hunedoara, ROMANIA  
<http://acta.fih.upt.ro>